

## Android Based Garage Gate Control System through IOT.

### About This Project:

The way our whole project works is that we take 220V AC from the main supply and feed it to a 12V step down transformer. The output of the transformer is 12V AC. Now, we give this 12V AC voltage to the rectifiers which are in full bridge rectifier formation. The output of the rectifier is 12V pulsating DC which is still not pure DC. So, to make this voltage pure DC, we give this voltage to a voltage smoothing capacitor. Now, the output is 12V pure DC but for our device's safety, we regulate this voltage down to 5V using a regulator IC. Now, we use this 5V DC voltage to run our NodeMCU which is the main brain of our circuit. The LCD unit and gear motor take power from the NodeMCU.

Now, let's talk about how the user commands the NodeMCU to do certain things. The thing is that the NodeMCU is connected to a server to which the user's phone is also connected. The server acts as the middleman to convey the user's command to the NodeMCU. The user uses an android app called "Blynk" to connect his phone to the common server and by clicking on the app, he sends the commands that the NodeMCU needs to perform. [Blynk is a Platform with IOS and Android apps to control Arduino, Raspberry Pi and the likes over the Internet. It's a digital dashboard where you can build a graphic interface for your project by simply dragging and dropping widgets.]

After the user completes connecting his phone with the NodeMCU, he commands the NodeMCU to open the gate using the Blynk app from his phone. After receiving the command, the NodeMCU starts working on the command. Now, let's talk about the mechanism of our garage door. Ours is a customized sliding garage doors work somewhat differently. These doors typically use a single garage door horizontal track that the door slides back on. Whether the door is a single unit or splits into two parts, it uses this track to open and conceal itself, then slide back as needed. The track is carefully installed and the full weight of the garage door is balanced on this track, supported by rubber-encased ball bearings created for maximum durability. Here, both the precise balance and power of gravity work in the garage door's favor: Opening the door takes very little energy, and it can easily be done by hand (even by the elderly) if necessary.

This design also helps reduce tension and wear that traditional garage doors can suffer from, making the door safer to use and less prone to failure or other issues. After the gate has been opened, the LCD

#### Office:

Road#04, Plot#03, Sec#6/Ka,  
Mirpur-2, Dhaka-1216

#### Web & Mail:

[www.projects.zeronebd.com](http://www.projects.zeronebd.com)  
[projects.zeronebd@gmail.com](mailto:projects.zeronebd@gmail.com)

#### Contact:

01676 99 80 99  
01714 80 84 02

unit shows that information and also when the door is closed that information can also be seen by looking at the LCD unit.

### Block Diagram:

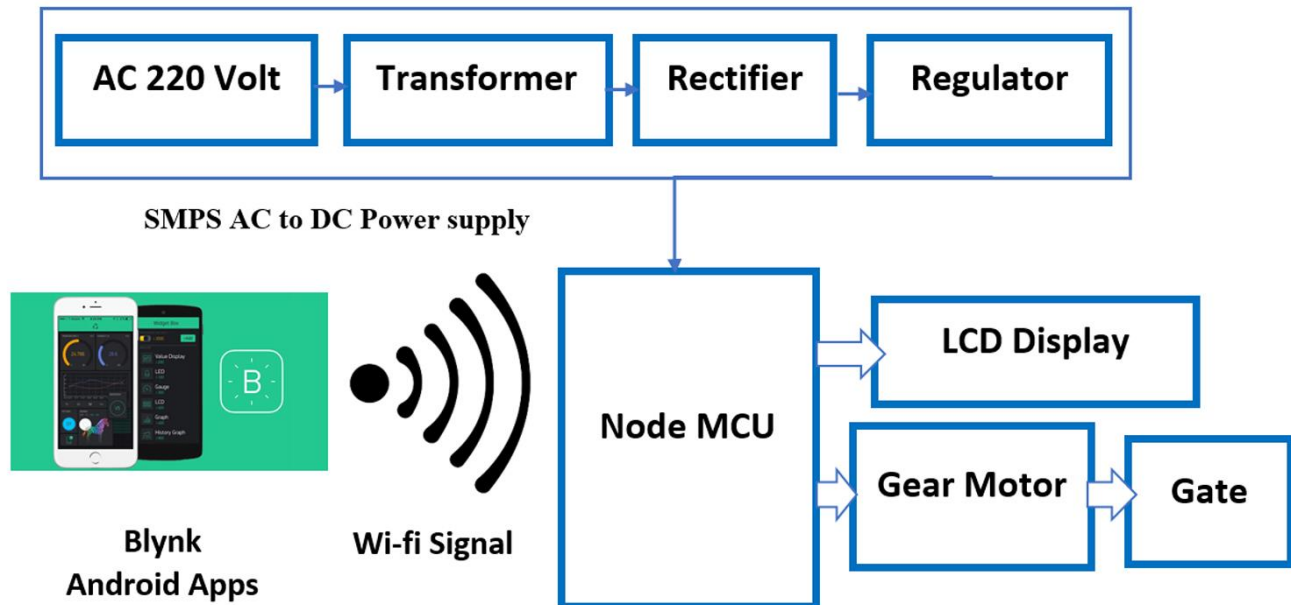

Figure: Block Diagram of Android Based Garage Gate Control System through IOT.

### Required Instrument:

- Node MCU.
- SMPS.
- Gear Box
- Belt
- Screw Nut
- LCD Display.
- Gear Motor.
- Transistor.
- Capacitor.
- Diode.
- Voltage Regulator.
- Resistor.
- PCB.

#### Office:

Road#04, Plot#03, Sec#6/Ka,  
Mirpur-2, Dhaka-1216

#### Web & Mail:

[www.projects.zeronebd.com](http://www.projects.zeronebd.com)  
[projects.zeronebd@gmail.com](mailto:projects.zeronebd@gmail.com)

#### Contact:

01676 99 80 99  
01714 80 84 02

## Advantages:

There are many advantages of our project because of its accuracy. Some of the advantages are pointed out below:

- The whole system is automatic and user-friendly. The setup is compact and small.
- The products used for building the project are all available in the market so maintenance is not a major issue.
- It can be said that the system is IoT enabled as we have connected the system to the Internet through the NodeMCU and also due to this, in future, more features can be added to this existing project.
- The availability of the Internet means that this project can be operated virtually from almost anywhere.
- This project is also helpful for people with physical disabilities as well. As they won't have to do much to open the garage door.

## Applications:

The application areas for this project in this modern and practical world are huge and some of these are given below:

- We can use this system for industrial purposes.
- It can be used in houses and hospital where physically challenged people live.
- This system can be used anywhere where there's a need for security and machine control.
- It can be used in shopping malls as well.

**N.B:** *Any modification of this project can be done as per your requirement. We will make the project according to your needs. Contact us with your any innovative engineering projects idea. We will help you to implement your project.*

### Office:

Road#04, Plot#03, Sec#6/Ka,  
Mirpur-2, Dhaka-1216

### Web & Mail:

www.projects.zeronebd.com  
projects.zeronebd@gmail.com

### Contact:

01676 99 80 99  
01714 80 84 02